

# HB2000GKFaPo



## At a glance

LIFTING	
manual	✓
Compact hydraulic system	✗
Hydrobull pump	✓
electric	✗

DRIVING	
manual	✓
Steering handle	✗
FaPo	✓
electric	✗

OPERATING FREQUENCY	
up to 10 times per month	✗
up to 25 times per month	✗
up to 100 times per month	✓
more than 100 times per month	✗

LIFTING CAPACITY WITH HORIZONTAL JIB		
	max. 2000 kg in front of the wheels	✓
	155 kg at 3125 mm in front of the wheels	✓

This original Hydrobull crane with counterweight have a rear-mounted chassis and a counterweight box. The counterweight allows it to directly approach loads and machines. The machines can be placed on full-length platforms or be very wide. All 13 positions are **in front of the wheels**, so the crane has an extremely clear outreach. The clear outreach and the large lifting height allow the cranes to be used frequently for tool changes and maintenance work (also above machine installations or under the ceiling). The counterweight crane was designed to provide a long service life even with frequent use.

### LIFTING/LOWERING



Secured to a high-quality galvanised DIN-standard swivel hook with the original **Hydrobull pump with 4 power/lift settings**. The detailed description can be found in our Technical Information Sheet 1.

### Driving



Manually supported by the Hydrobull mechanical **driving positioning device, FaPo®** for short. The detailed description can be found in our Technical Information Sheet 1.

### JIB

Has 13 setting which can be easily selected via 2two separate galvanized jibs using a socket pin system. In addition, the jibs are secured with a squeeze-out lock to prevent accidents due to unintentional falling out.

### PARKING

Is done easily and conveniently by turning a lever mounted on the guard of the FaPo steering wheel. **Manual machines are generally** not equipped with a travel brake.

### COUNTERWEIGHT

#### ATTENTION!

Only use with filled box!  
You can fill the box with steel plates yourself.



The empty counterweight box is supplied fitted on the crane and is removable. On the right and left side are openings for attaching suitable lifting aids. After filling, these openings can be closed with the plastic caps supplied, so that no weight is lost. The counterweight box also has a lid for closing. The lid has a device that allows you to lock it with a customer-supplied padlock. On request, we can fill the counterweight box for an additional charge. It is delivered as a separate package on a pallet and must be placed on the crane by you using suitable lifting equipment.

### OTHER

- Seal kits and other spare parts are available ex stock for both the cylinder and the pump
- Modern, protected design – only from Hydrobull
- Delivery incl. inspection book and operating instructions
- German Product
- Euronorm 2006/42/EC and DGUV68
- **2 Year Warranty**
- Spare parts for older machines on request

**Technical Drawings**

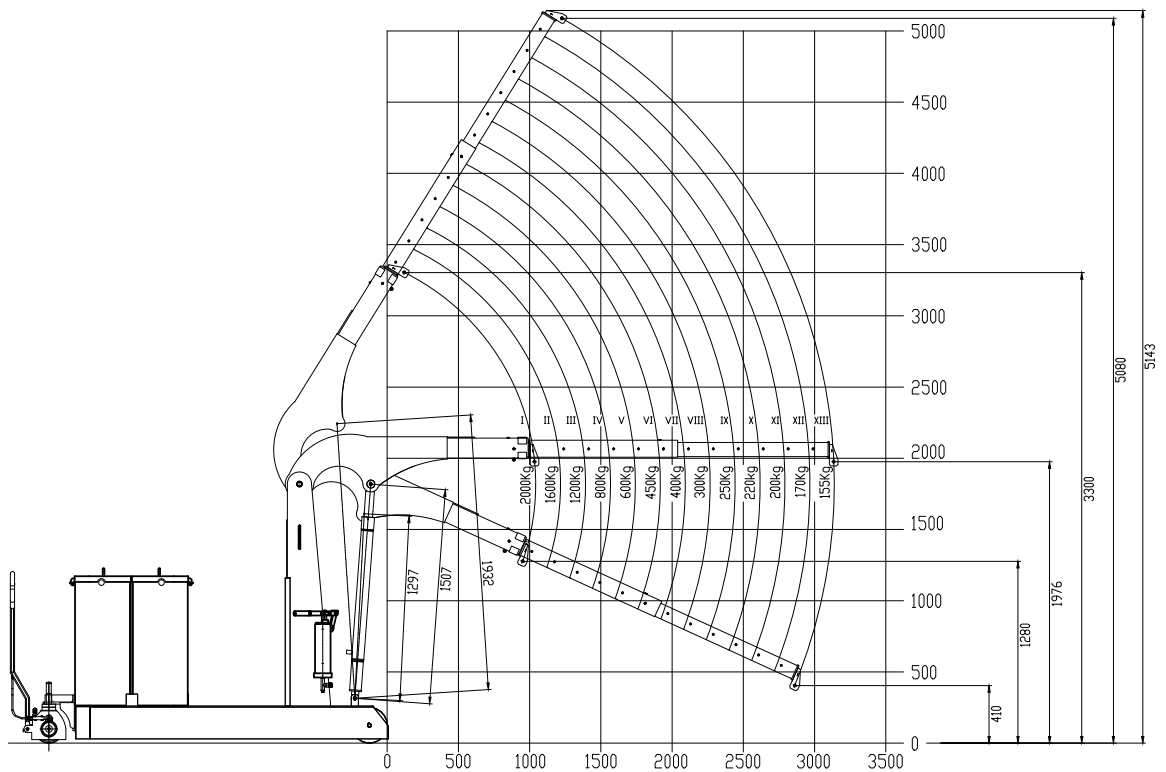
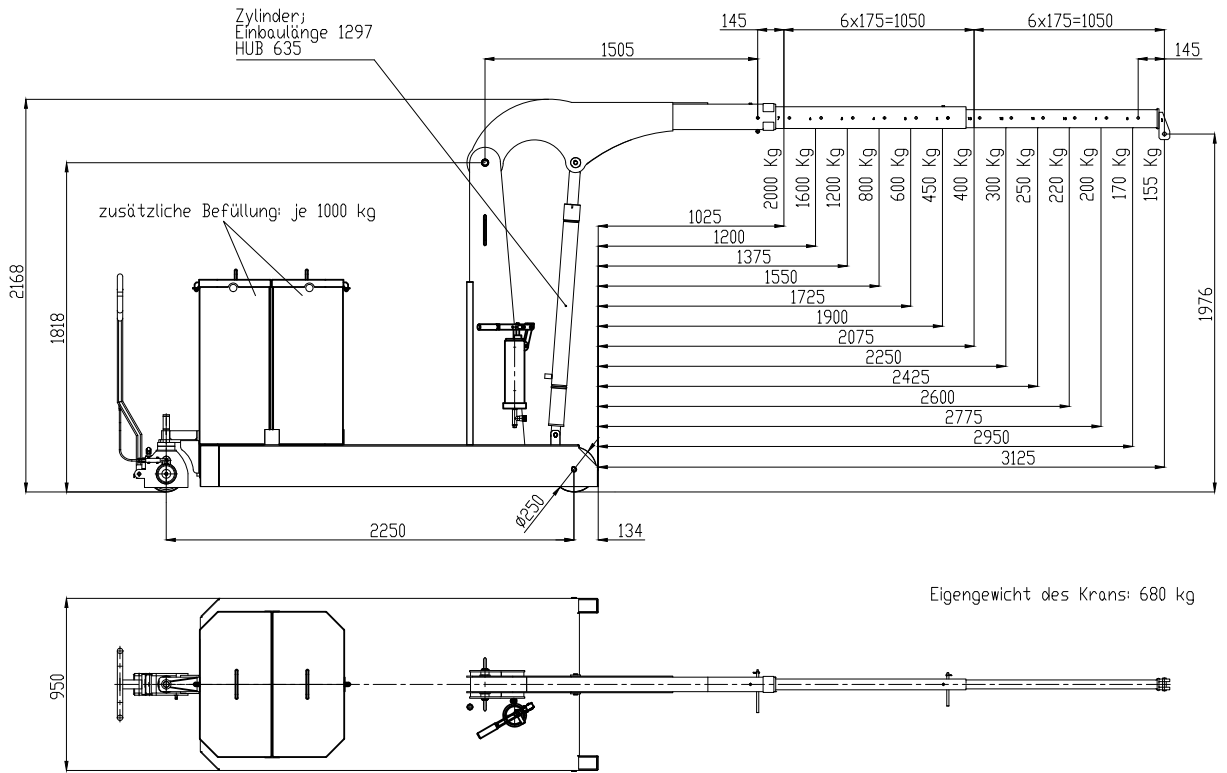

Subject to technical modifications. Data subject to manufacturing tolerances.

## Technical specifications

### RATIO LIFTING CAPACITY, OUTREACH, LIFTING HEIGHT

Jib Position	Lifting capacity/kg	Load with horizontal jib/mm		Lift height*/mm	
		in front of the hydraulic system approx.	in front of the wheels approx.	min.	max.
1	2000	1075	1025	1010	3030
2	1600	1250	1200	930	3170
3	1200	1425	1375	850	3310
4	800	1600	1550	770	3450
5	600	1825	1725	700	3600
6	450	1950	1900	630	3760
7	400	2125	2075	575	3920
8	300	2300	2250	520	4080
9	250	2475	2425	450	4240
10	220	2650	2600	380	4390
11	200	2825	2775	300	4530
12	170	3000	2950	220	4670
13	155	3175	3125	140	4810

\* at hook mouth opening - please refer to the diagram for the reduced outreach

### OTHER DETAILS

		min.	max.
Jib length from... to...		1650	3750
Length of wheelbase	mm		2250
Length of chassis incl. wheels	mm		2620
Length incl. inserted lowered jib Pos. 1	mm		3670
approx. aisle width for 90° turn	mm		3600
Width of chassis external	mm		950
Width of chassis internal	mm		-
Clearance height, jib horizontal	mm		2170
Clearance height, jib lowered	mm		2080
Clearance	mm		-
Hook length approx.	mm		330
Ground clearance	mm		30
Load wheel	mm		250
Steering wheel	mm		200
Slewing			-
Tare weight - for counterweight cranes incl. empty box	kg		740
Required filling weight for counterweight cranes**	kg		2000
Batteries			-

\*\* Machine can only be used when installed