

HB500GKB18FaPo



At a glance

LIFTING	
manual	✗
Compact hydraulic system	✗
Hydrobull pump	✗
electric	✓

DRIVING	
manual	✓
Steering handle	✗
FaPo	✓
electric	✗

OPERATING FREQUENCY	
up to 10 times per month	✗
up to 25 times per month	✗
up to 100 times per month	✗
more than 100 times per month*	✓

LIFTING CAPACITY WITH HORIZONTAL JIB		
	max. 500 kg in front of the wheels	✓
	95 kg at 2530 mm in front of the wheels	✓

This extremely short original Elektrobull crane with counterweight has a rear-mounted chassis with counterweight box which allows it to directly approach loads and machines. The battery electric lift with cable remote control allows the operator to lift or lower the load from any point on the crane. The short crane is also equipped with a driving positioning device (FaPo) developed by Hydrobull for driving support.

LIFTING/LOWERING



Secured on the high-quality, galvanized DIN safety hook **battery-powered at the push of a button on the manual switch**. Using the manual switch with approx. 3 metres of cable, the operator can flexibly operate the lifting and lowering independently of the crane. This means You can stand close to the load to observe or assist the exact fitting. This gives more security and allows tasks to be completed faster

DRIVING



Manually supported by the Hydrobull mechanical **driving positioning device, FaPo®** for short. The detailed description can be found in our Technical Information Sheet 1.

JIB

Has 13 setting which can be easily selected via 2two separate galvanized jibs using a socket pin system. In addition, the jibs are secured with a squeeze-out lock to prevent accidents.

PARKING

The machine is easily and conveniently locked in place by turning a lever on the FaPo steering wheel. Manual machines are generally not equipped with a travel brake.

COUNTERWEIGHT

ATTENTION!

Only use with filled box!
You can fill the box with steel plates yourself.



The empty counterweight box is supplied fitted on the crane and is removable. On the right and left side are openings for attaching suitable lifting aids. After filling, these openings can be closed with the plastic caps supplied, so that no weight is lost. The counterweight box also has a lid for closing. The lid has a device that allows you to lock it with a customer-supplied padlock. On request, we can fill the counterweight box for an additional charge. It is delivered as a separate package on a pallet and must be placed on the crane by you using suitable lifting equipment.

OTHER

- Modern, protected design - only from Hydrobull
- Delivery incl. inspection book and operating instructions
- German Product
- Euronorm 2006/42/EC and DGUV68
- **2 Year Warranty**

Want to learn more about the benefits of our electric cranes? Our **Technical Information Sheet 2** contains more information.

Technical Drawings HB500GKB18FaPo

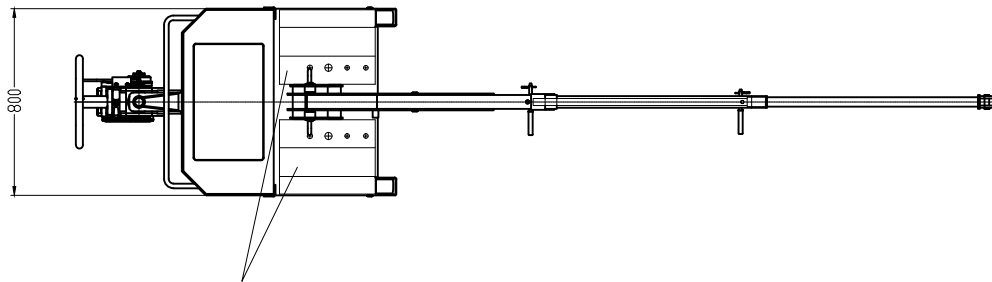
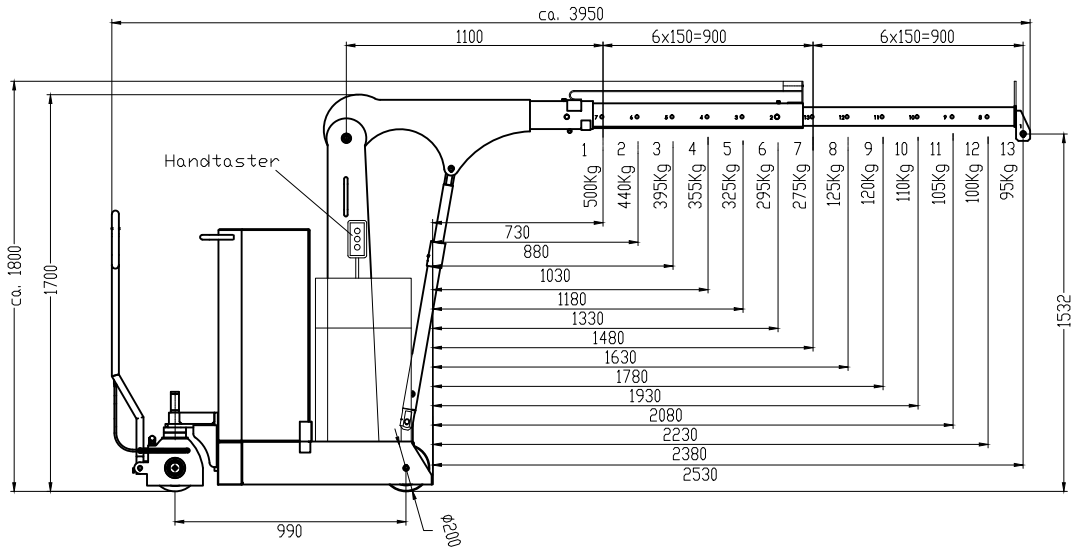

Elektrohydraulische Einheit

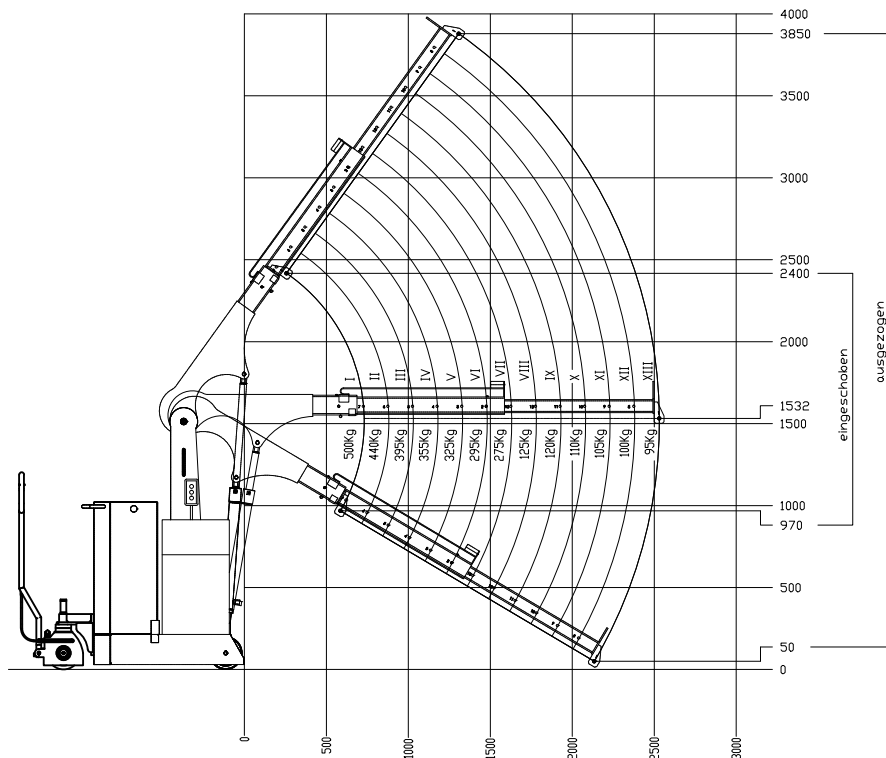

Subject to technical modifications. Data subject to manufacturing tolerances.

Technical specifications HB500GKB18FaPo

RATIO LIFTING CAPACITY, OUTREACH, LIFTING HEIGHT

Jib Position	Lifting capacity/kg	Load with horizontal jib/mm		Lift height*/mm	
		in front of the hydraulic system approx.	in front of the wheels approx.	min.	max.
1	500	630	730	780	2240
2	440	780	880	700	2360
3	395	930	1030	620	2480
4	355	1080	1180	540	2600
5	325	1230	1330	465	2720
6	295	1380	1480	390	2840
7	275	1530	1630	320	2960
8	125	1680	1780	245	3080
9	120	1830	1930	170	3200
10	110	1980	2080	100	3320
11	105	2130	2230	30	3440
12	100	2280	2380	0	3560
13	95	2430	2530	0	3680

* at hook mouth opening - please refer to the diagram for the reduced outreach

OTHER DETAILS		min.	max.
Jib length from... to...		1100	2900
Length of wheelbase	mm		990
Length of chassis incl. wheels	mm		1400
Length incl. inserted lowered jib Pos. 1	mm		2000
approx. aisle width for 90° turn	mm		1600
Width of chassis external	mm		800
Width of chassis internal	mm		-
Clearance height, jib horizontal	mm		1700
Clearance height, jib lowered	mm		1670
Clearance	mm		-
Hook length approx.	mm		225
Ground clearance	mm		30
Load wheel	mm		200
Steering wheel	mm		200
Slewing			-
Tare weight - for counterweight cranes incl. empty box	kg		400
Required filling weight for counterweight cranes**	kg		1120
Batteries	Ah		95
Charger - external	A		10

** Machine can only be used when installed