

HB2000GKBRP



At a glance

LIFTING		DRIVING		OPERATING FREQUENCY	
manual	✘	manual	✘	up to 10 times per month	✘
Compact hydraulic system	✘	Steering handle	✘	up to 25 times per month	✘
Hydrobull pump	✘	FaPo	✘	up to 100 times per month	✘
electric	✔	electric	✔	more than 100 times per month	✔

LIFTING CAPACITY WITH HORIZONTAL JIB		
	max. 2000 kg in front of the wheels	✔
	440 kg at 3125 mm in front of the wheels	✔

These original Elektrobull counterweight cranes with rear-mounted chassis and counterweight box can directly approach loads and machines. The battery electric lift with cable remote control allows the operator to lift or lower the load from any point on the crane. In addition, the Elektrobull is equipped with a battery electric drive. One person alone can comfortably move the machine even over longer distances.

LIFTING/LOWERING

Secured to a high-quality galvanised DIN safety swivel hook **electrically with the push of a button on the manual switch** or with the steering handle.

Driving

Sensitive adjustment with 2 KW **electric drive** with all necessary safety features.

JIB

Has 13 setting which can be easily selected via 2two separate galvanized jibs using a socket pin system.

In addition, the jibs are secured with a squeeze-out lock to prevent accidents due to unintentional falling out.

BRAKING

By releasing the steering handle or vertical or horizontal positions, the machine brakes automatically.

After the work is done, the machine can be parked safely by removing the key.

COUNTERWEIGHT

ATTENTION!

Only use with filled box!

You can fill the box with steel plates yourself.



The empty counterweight box is supplied fitted on the crane and is removable.

On the right and left side are openings for attaching suitable lifting aids. After filling, these openings can be closed with the plastic caps supplied, so that no weight is lost. The counterweight box also has a lid for closing. The lid has a device that allows you to lock it with a customer-supplied padlock.

On request, we can fill the counterweight box for an additional charge. It is delivered as a separate package on a pallet and must be placed on the crane by you using suitable lifting equipment.

OTHER

- Modern, protected design – only from Hydrobull
- Delivery incl. inspection book and operating instructions
- German Product
- Euronorm 2006/42/EC and DGUV68
- **2 Year Warranty**

If you are interested in discovering further advantages and more detailed descriptions of the electric cranes, please refer to our **Technical Information Sheet 2**.

Technical Drawings HB2000GKBRP

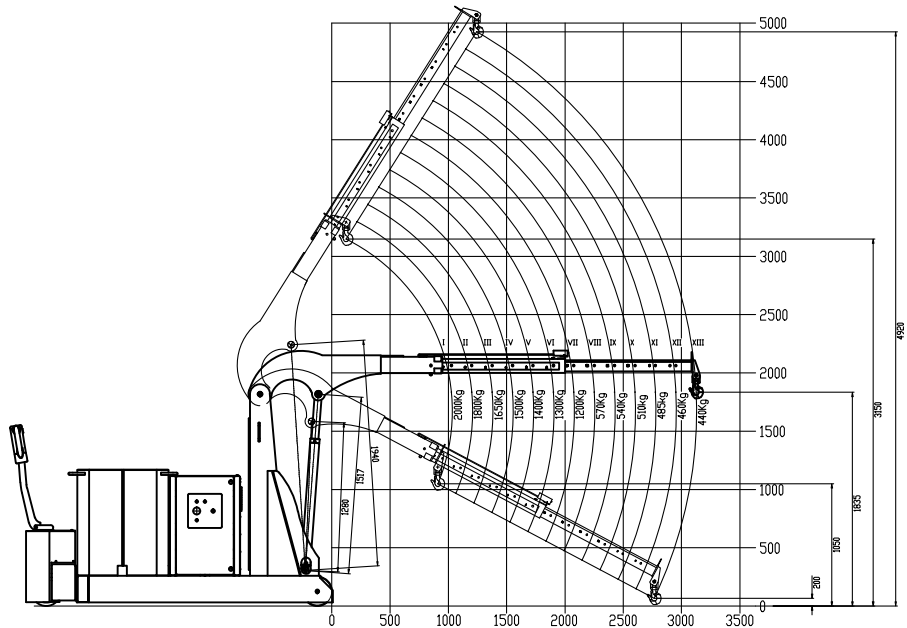
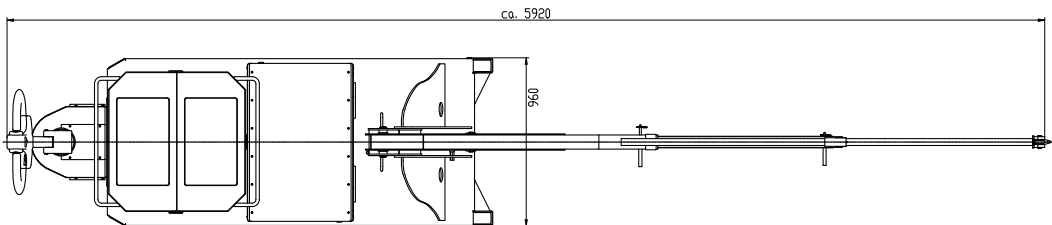
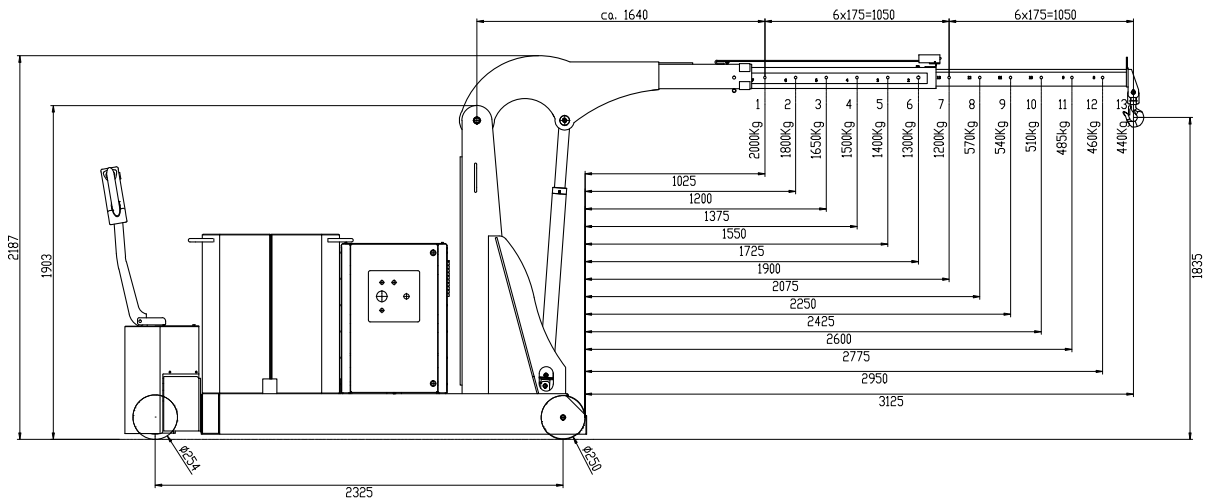

Technical specifications HB2000GKBRP

RATIO LIFTING CAPACITY, OUTREACH, LIFTING HEIGHT

Jib Position	Lifting capacity/kg	Load with horizontal jib/mm		Lift height*/mm	
		in front of the hydraulic system approx.	in front of the wheels approx.	min.	max.
1	2000	1075	1025	1050	3150
2	1800	1250	1200	980	3295
3	1650	1425	1375	910	3440
4	1500	1600	1550	840	3585
5	1400	1825	1725	770	3735
6	1300	1950	1900	700	3885
7	1200	2125	2075	625	4035
8	570	2300	2250	550	4185
9	540	2475	2425	480	3445
10	510	2650	2600	410	4485
11	485	2825	2775	340	4630
12	460	3000	2950	270	4775
13	440	3175	3125	200	4920

* at hook mouth opening - please refer to the diagram for the reduced outreach

OTHER DETAILS		min.	max.
Jib length from... to...		1650	3750
Length of wheelbase	mm		2400
Length of chassis incl. wheels	mm		2700
Length incl. inserted lowered jib Pos. 1	mm		4500
approx. aisle width for 90° turn	mm		3000
Width of chassis external	mm		1000
Width of chassis internal	mm		-
Clearance height, jib horizontal	mm		2180
Clearance height, jib lowered	mm		2000
Clearance	mm		-
Hook length approx.	mm		330
Ground clearance	mm		30
Load wheel	mm		250
Steering wheel	mm		254
Slewing			-
Tare weight - for counterweight cranes incl. empty box	kg		1050
Required filling weight for counterweight cranes**	kg		2000
Batteries	Ah		2 x 180
Charger - inbuilt	A		30

** Machine can only be used when installed